

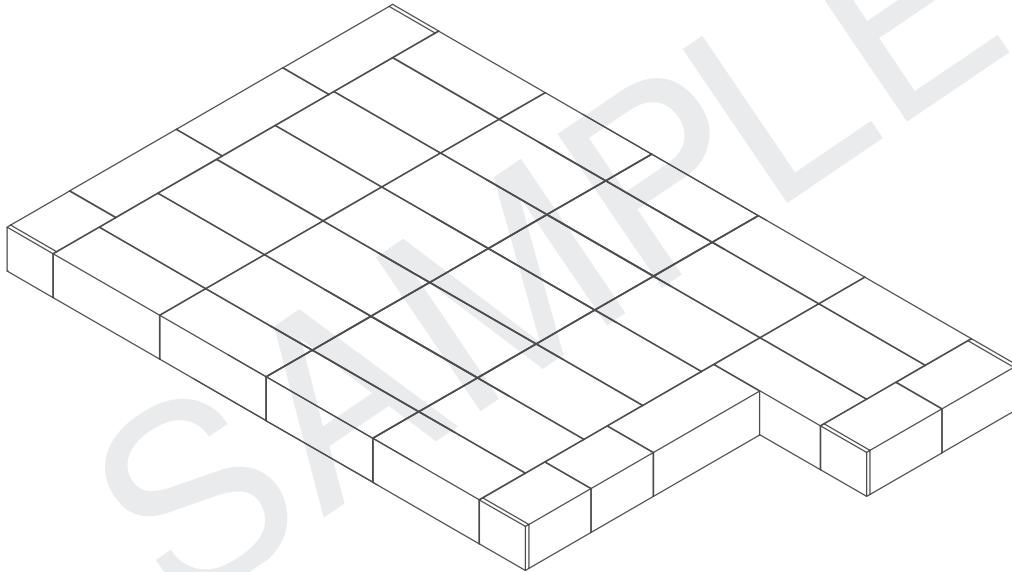

StormTrap®
 MODULAR CONCRETE
 STORMWATER MANAGEMENT

CONTACT STORMTRAP TO REQUEST A DESIGN AND BUDGET FOR YOUR SPECIFIC PROJECT NEEDS.



SHEET INDEX	
PAGE	DESCRIPTION
0.0	COVER SHEET
1.0	SINGLETRAP DESIGN CRITERIA
2.0	SINGLETRAP SYSTEM LAYOUT
2.1	SINGLETRAP FOUNDATION LAYOUT
3.0	SINGLETRAP INSTALLATION SPECIFICATIONS
3.1	SINGLETRAP INSTALLATION SPECIFICATIONS
4.0	SINGLETRAP BACKFILL SPECIFICATIONS
5.0	RECOMMENDED PIPE / ACCESS OPENING SPECIFICATIONS
6.0	SINGLETRAP MODULE TYPES

STORMTRAP CONTACT INFORMATION	
STORM TRAP SUPPLIER:	STORMTRAP
CONTACT NAME:	STORMTRAP
CELL PHONE:	STORMTRAP
SALES EMAIL:	STORMTRAP

StormTrap®
 PATENTS LISTED AT: [HTTP://STORMTRAP.COM/PATENT]
 1-877-867-6872

ENGINEER INFORMATION:
 [Empty box]

PROJECT INFORMATION:
 SINGLETRAP
 DETENTION

CURRENT ISSUE DATE:
 [Empty box]

ISSUED FOR:
 SAMPLE PROJECT

REV.	DATE:	ISSUED FOR:	DWN BY:

SCALE:
 NTS

SHEET TITLE:
 COVER SHEET

SHEET NUMBER:
0.0

**SINGLETRAP® - DETENTION
 SAMPLE DRAWING**

STORMTRAP SYSTEM INFORMATION

WATER STORAGE REQ'D: 20000 CUBIC FEET
 WATER STORAGE PROV: 21379.17 CUBIC FEET
 UNIT HEADROOM: 5' 0" SINGLETRAP
 UNIT QUANTITY: 42 TOTAL PIECES

STORMTRAP STRUCTURAL DESIGN CRITERIA

1. STORMTRAP MODULES SHALL BE MANUFACTURED AND INSTALLED ACCORDING TO SHOP DRAWINGS APPROVED BY THE INSTALLING CONTRACTOR AND ENGINEER OF RECORD. THE SHOP DRAWINGS SHALL INDICATE SIZE AND LOCATION OF ROOF OPENINGS AND INLET/ OUTLET PIPE TYPES, SIZES, INVERT ELEVATIONS AND SIZE OF OPENINGS.
2. COVER RANGE: MIN. 1.08' MAX. 10.00'(CONSULT STORMTRAP FOR ADDITIONAL COVER OPTIONS).
3. ALL DIMENSIONS AND SOIL CONDITIONS, INCLUDING BUT NOT LIMITED TO GROUNDWATER AND SOIL BEARING CAPACITY ARE REQUIRED TO BE VERIFIED IN THE FIELD BY OTHERS PRIOR TO STORMTRAP INSTALLATION.

StormTrap®

PATENTS LISTED AT: [HTTP://STORMTRAP.COM/PATENT/]

1-877-867-6872

ENGINEER INFORMATION:

[Empty box for Engineer Information]

PROJECT INFORMATION:

SINGLETRAP
 DETENTION

CURRENT ISSUE DATE:

[Empty box for Current Issue Date]

ISSUED FOR:

SAMPLE PROJECT

REV.	DATE:	ISSUED FOR:	DWN BY:

SCALE:

NTS

SHEET TITLE:

SINGLETRAP
 DESIGN
 CRITERIA

SHEET NUMBER:

1.0

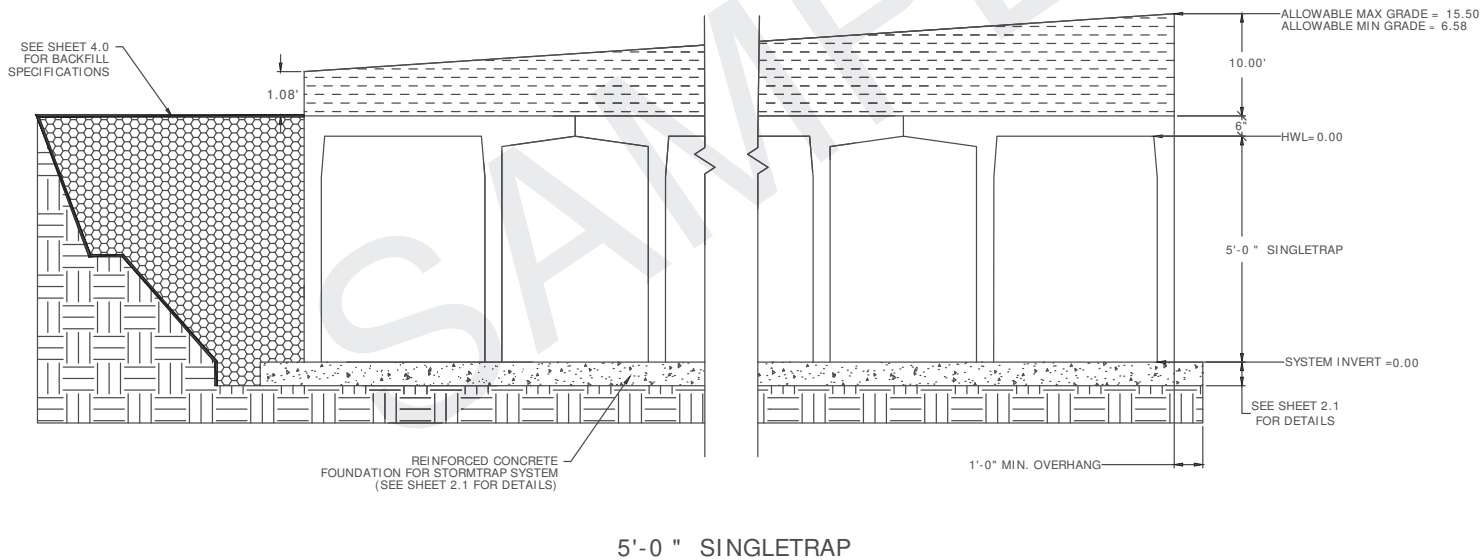

BILL OF MATERIALS

QTY.	UNIT TYPE	DESCRIPTION	WEIGHT
21	I	5' 0" SINGLETRAP	
0	II	5' 0" SINGLETRAP	
13	III	5' 0" SINGLETRAP	
3	IV	5' 0" SINGLETRAP	
0	VII	5' 0" SINGLETRAP	
5	SPIV	5' 0" SINGLETRAP	
5	PANEL	8" THICK PANELS	
8	JOINTWRAP	150' PER ROLL	
32	JOINTTAPE	14.5' PER ROLL	

DESIGN CRITERIA
 ALLOWABLE MAX GRADE = 15.50
 ALLOWABLE MIN GRADE = 6.58
 INSIDE HEIGHT ELEVATION = 0.00
 SYSTEM INVERT = 0.00
 STORMTRAP VOLUME = 21379.17 C.F.

- NOTES:**
- DIMENSIONING OF STORMTRAP SYSTEM SHOWN BELOW ALLOW FOR A 3/4" GAP BETWEEN EACH MODULE.
 - ALL DIMENSIONS TO BE VERIFIED IN THE FIELD BY OTHERS.
 - SEE SHEET 3.0 FOR INSTALLATION SPECIFICATIONS.
 - SP - INDICATES A MODULE WITH MODIFICATIONS.
 - P - INDICATES A MODULE WITH A PANEL ATTACHMENT.
 - CONTRACTORS RESPONSIBILITY TO ENSURE CONSISTENCY/ACCURACY TO FINAL ENGINEER OF RECORD PLAN SET.

StormTrap®

PATENTS LISTED AT: [HTTP://STORMTRAP.COM/PATENT]

1-877-867-6872

ENGINEER INFORMATION:

PROJECT INFORMATION:

SINGLETRAP

DETENTION

CURRENT ISSUE DATE:

ISSUED FOR:

SAMPLE PROJECT

REV.	DATE:	ISSUED FOR:	DWN BY:

SCALE:

NTS

SHEET TITLE:

SINGLETRAP
SYSTEM LAYOUT

SHEET NUMBER:

2.0

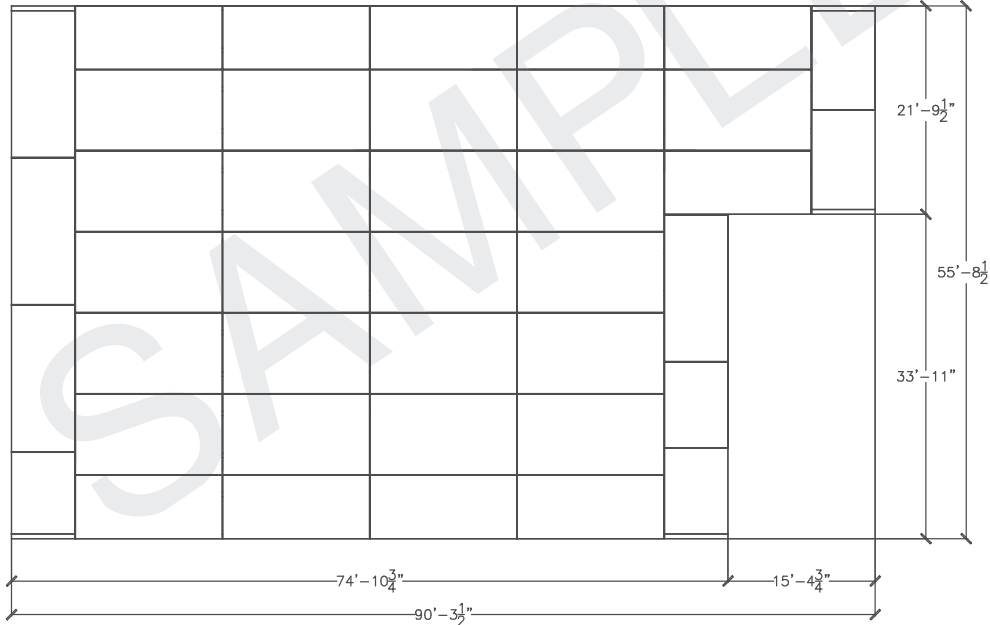

ENGINEER INFORMATION:

[Empty box for Engineer Information]

PROJECT INFORMATION:

SINGLETRAP
DETENTION

CURRENT ISSUE DATE:

[Empty box for Current Issue Date]

ISSUED FOR:

SAMPLE PROJECT

REV.	DATE:	ISSUED FOR:	DWN BY:

SCALE:

NTS

SHEET TITLE:

SINGLETRAP
FOUNDATION LAYOUT

SHEET NUMBER:

2.1

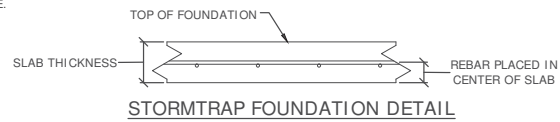
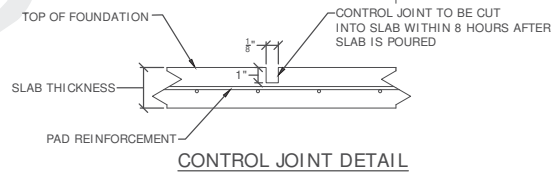
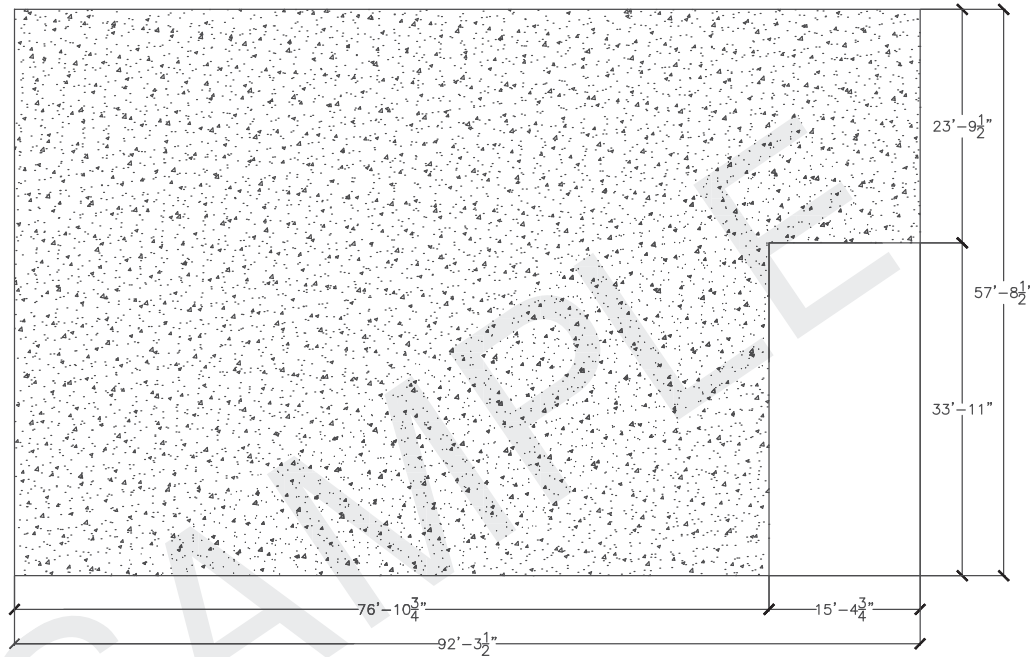

MAXIMUM SYSTEM COVER	SLAB THICKNESS	CONCRETE STRENGTH	REINFORCEMENT (BOTH DIRECTIONS)
6" - 12"	0'-8"	4000 PSI	# 4 @ 18" O.C.
> 1'-0" - 2'-0"	0'-8"	4000 PSI	# 4 @ 16" O.C.
> 2'-0" - 3'-0"	0'-8"	4000 PSI	# 4 @ 12" O.C.
> 3'-0" - 4'-0"	0'-8"	4000 PSI	# 4 @ 12" O.C.
> 4'-0" - 5'-0"	0'-8"	4000 PSI	# 5 @ 18" O.C.
> 5'-0" - 6'-0"	0'-8"	4000 PSI	# 5 @ 16" O.C.
> 6'-0" - 7'-0"	0'-8"	4000 PSI	# 5 @ 16" O.C.
> 7'-0" - 8'-0"	0'-9"	4000 PSI	# 5 @ 12" O.C.
> 8'-0" - 9'-0"	0'-10"	4000 PSI	# 5 @ 12" O.C.
> 9'-0" - 10'-0"	0'-10"	4500 PSI	# 5 @ 12" O.C.

NOTES:

1. CONCRETE STRENGTH @ 28 DAYS, 5%-8% ENTRAINED AIR, 4" MAX. SLUMP.
2. NET ALLOWABLE SOIL PRESSURE AS INDICATED ON SHEET 1.0.
3. SOIL CONDITIONS TO BE VERIFIED ON SITE BY OTHERS.
4. REBAR: ASTM A-615 GRADE 60. BLACK BAR.
5. DIMENSION OF FOUNDATION MUST HAVE 1'-0" OVERHANG BEYOND EXTERNAL FACE OF MODULE.
6. DIMENSION OF STORMTRAP SYSTEM ALLOW FOR A 3/4" GAP BETWEEN EACH MODULE.
7. ALL DIMENSIONS TO BE VERIFIED IN THE FIELD BY OTHERS.
8. THE CONTROL JOINTS SHALL BE BETWEEN (IF REQUIRED BY ENGINEER OF RECORD) 16'-0" TO 24'-0" MAX APART.
9. SEE SHEET 3.0 FOR INSTALLATION SPECIFICATIONS.

STORMTRAP INSTALLATION SPECIFICATIONS

1. STORMTRAP SHALL BE INSTALLED IN ACCORDANCE WITH ASTM C891, STANDARD FOR INSTALLATION OF UNDERGROUND PRECAST CONCRETE UTILITY STRUCTURES, THE FOLLOWING ADDITIONS AND/OR EXCEPTIONS SHALL APPLY:
2. IT IS THE RESPONSIBILITY OF THE INSTALLING CONTRACTOR TO ENSURE THAT PROPER/ADEQUATE EQUIPMENT IS USED TO SET/INSTALL THE MODULES.
3. STORMTRAP MODULES SHALL BE PLACED ON A LEVEL CONCRETE FOUNDATION (SEE SHEET 2.1) WITH A 1'-0" OVERHANG ON ALL SIDES THAT SHALL BE POURED IN PLACE BY INSTALLING CONTRACTOR. A QUALIFIED GEOTECHNICAL ENGINEER WILL BE EMPLOYED, BY OWNER, TO PROVIDE ASSISTANCE IN EVALUATING THE EXISTING SOIL CONDITIONS. TO ENSURE THAT HE SOIL BEARING PRESSURE MEET OR EXCEED THE STRUCTURAL DESIGN LOADING CRITERIA AS SPECIFIED ON SHEET 1.0.
4. THE STORMTRAP MODULES SHALL BE PLACED SUCH THAT THE MAXIMUM SPACE BETWEEN ADJACENT MODULES DOES NOT EXCEED $\frac{3}{4}$ " (SEE DETAIL 2). IF THE SPACE EXCEEDS $\frac{3}{4}$ ", THE MODULES SHALL BE RESET WITH APPROPRIATE ADJUSTMENT MADE TO LINE AND GRADE TO BRING THE SPACE INTO SPECIFICATION.
5. THE PERIMETER HORIZONTAL JOINT BETWEEN THE STORMTRAP MODULES AND THE CONCRETE FOUNDATION SHALL BE SEALED TO THE FOUNDATION WITH PRE-FORMED MASTIC JOINT SEALER ACCORDING TO ASTM C891, 8.8 AND 8.12 (SEE DETAIL 1). THE MASTIC JOINT TAPE DOES NOT PROVIDE A WATERTIGHT SEAL. THE SOLE PURPOSE OF THE JOINT TAPE IS TO PROVIDE A SILT AND SOIL TIGHT SYSTEM.
6. STORMTRAP MODULES ARE NOT WATERTIGHT. IF A WATERTIGHT SOLUTION IS REQUIRED, CONTACT STORMTRAP FOR RECOMMENDATIONS. THE WATERTIGHT APPLICATION IS TO BE PROVIDED AND IMPLEMENTED BY THE CONTRACTOR. THE CONTRACTOR IS RESPONSIBLE TO ENSURE THAT THE SELECTED WATERTIGHT SOLUTION PERFORMS AS SPECIFIED BY THE MANUFACTURER. CONTACT STORMTRAP IF A WATERTIGHT APPLICATION IS REQUIRED.
7. ALL EXTERIOR JOINTS BETWEEN ADJACENT STORMTRAP MODULES SHALL BE SEALED WITH 8" WIDE PRE-FORMED, COLD-APPLIED, SELF-ADHERING ELASTOMERIC RESIN, BONDED TO A WOVEN, HIGHLY PUNCTURE RESISTANT POLYMER WRAP, CONFORMING TO ASTM C891 AND SHALL BE INTEGRATED WITH PRIMER SEALANT AS APPROVED BY STORMTRAP (SEE DETAILS 3 & 4). THE JOINT WRAP DOES NOT PROVIDE A WATERTIGHT SEAL. THE SOLE PURPOSE OF THE JOINT WRAP IS TO PROVIDE A SILT AND SOIL TIGHT SYSTEM. THE ADHESIVE EXTERIOR JOINT WRAP SHALL BE INSTALLED ACCORDING TO THE FOLLOWING INSTALLATION INSTRUCTIONS:
 - 7.1. USE A BRUSH OR WET CLOTH TO THOROUGHLY CLEAN THE OUTSIDE SURFACE AT THE POINT WHERE JOINT WRAP IS TO BE APPLIED.
 - 7.2. A RELEASE PAPER PROTECTS THE ADHESIVE SIDE OF THE JOINT WRAP. PLACE THE ADHESIVE TAPE (ADHESIVE SIDE DOWN) AROUND THE STRUCTURE, REMOVING THE RELEASE PAPER AS YOU GO. PRESS THE JOINT WRAP FIRMLY AGAINST THE STORMTRAP MODULE SURFACE WHEN APPLYING.
8. IF THE CONTRACTOR NEEDS TO CANCEL ANY SHIPMENTS, THEY MUST DO SO 48 HOURS PRIOR TO THEIR SCHEDULED ARRIVAL AT THE JOB SITE. IF CANCELED AFTER THAT TIME, PLEASE CONTACT THE PROJECT MANAGER.
9. IF THE STORMTRAP MODULE(S) IS DAMAGED IN ANY WAY PRIOR, DURING, OR AFTER INSTALL, STORMTRAP MUST BE CONTACTED IMMEDIATELY TO ASSESS THE DAMAGE AND DETERMINE WHETHER OR NOT THE MODULE(S) WILL NEED TO BE REPLACED. IF ANY MODULE ARRIVES AT THE JOBSITE DAMAGED DO NOT UNLOAD IT; CONTACT STORMTRAP IMMEDIATELY. ANY DAMAGE NOT REPORTED BEFORE THE TRUCK IS UNLOADED WILL BE THE CONTRACTOR'S RESPONSIBILITY.
10. STORMTRAP MODULES CANNOT BE ALTERED IN ANY WAY AFTER MANUFACTURING WITHOUT WRITTEN CONSENT FROM STORMTRAP.

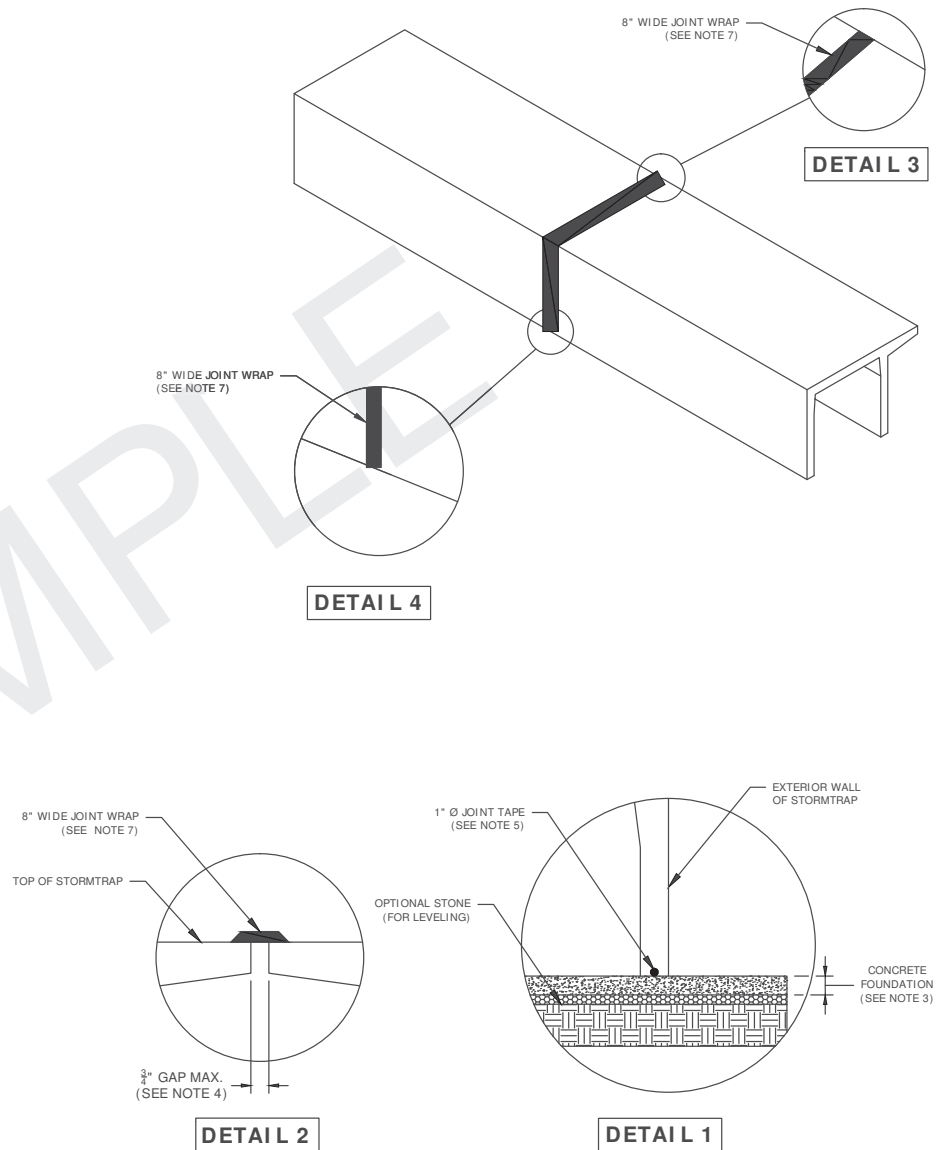

StormTrap®

PATENTS LISTED AT: [HTTP://STORMTRAP.COM/PATENT/](http://stormtrap.com/patent/)

1-877-867-6872

ENGINEER INFORMATION:

PROJECT INFORMATION:

SINGLETRAP

DETENTION

CURRENT ISSUE DATE:

ISSUED FOR:

SAMPLE PROJECT

REV.	DATE:	ISSUED FOR:	DWN BY:

SCALE:

NTS

SHEET TITLE:

SINGLETRAP
INSTALLATION
SPECIFICATIONS

SHEET NUMBER:

3.0

END PANEL ERECTION/INSTALLATION NOTES

1. END PANELS WILL BE SUPPLIED TO CLOSE OFF OPEN ENDS OF ROWS.
2. PANELS SHALL BE INSTALLED IN A TILT UP FASHION DIRECTLY ADJACENT TO OPEN END OF MODULE (REFER TO SHEET 2.0 FOR END PANEL LOCATIONS).
3. CONNECTION HOOKS WILL BE SUPPLIED WITH END PANELS TO SECURELY CONNECT PANEL TO ADJACENT STORMTRAP MODULE (SEE PANEL CONNECTION ELEVATION VIEW).
4. ONCE CONNECTION HOOKS ARE ATTACHED, LIFTING CLUTCHES MAY BE REMOVED.
5. JOINT WRAP SHALL BE PLACED AROUND PERIMETER JOINT PANEL (SEE SHEET 3.0).

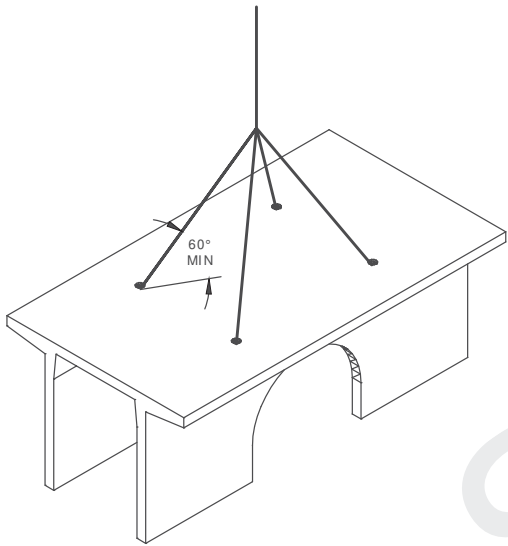

MODULE LIFTING DETAIL

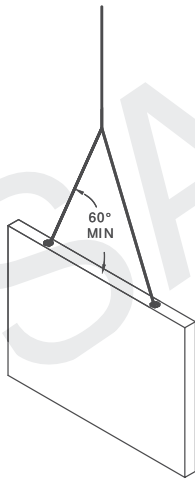

END PANEL LIFTING DETAIL

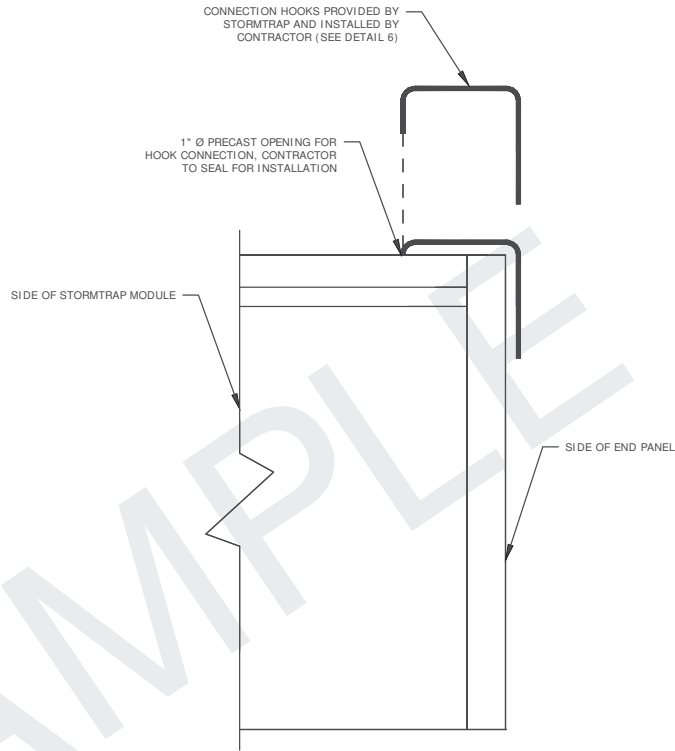

PANEL CONNECTION ELEVATION VIEW

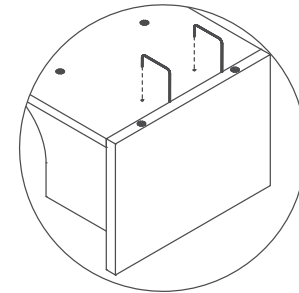

STEP 1

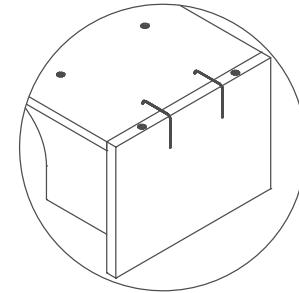

STEP 2

DETAIL 6

StormTrap®

PATENTS LISTED AT: [HTTP://STORMTRAP.COM/PATENT/](http://stormtrap.com/patent/)

1-877-867-6872

ENGINEER INFORMATION:

Blank box for Engineer Information.

PROJECT INFORMATION:

SINGLETRAP
DETENTION

CURRENT ISSUE DATE:

Blank box for Current Issue Date.

ISSUED FOR:

SAMPLE PROJECT

REV.	DATE:	ISSUED FOR:	DWN BY:

SCALE:

NTS

SHEET TITLE:

SINGLETRAP
INSTALLATION
SPECIFICATIONS

SHEET NUMBER:

3.1

ZONE CHART

ZONES	ZONE DESCRIPTIONS	REMARKS
ZONE 1 (OPTIONAL)	FOUNDATION AGGREGATE	
ZONE 2	BACKFILL	
ZONE 3	FINAL COVER OVERTOP	

STORMTRAP ZONE INSTALLATION SPECIFICATIONS/PROCEDURES

1. THE FILL PLACED AROUND THE STORMTRAP MODULES MUST DEPOSITED ON BOTH SIDES AT THE SAME TIME AND TO APPROXIMATELY THE SAME ELEVATION. AT NO TIME SHALL THE FILL BEHIND ONE SIDE WALL BE MORE THAN 2'-0" HIGHER THAN THE FILL ON THE OPPOSITE SIDE. BACKFILL SHALL EITHER BE COMPACTED AND/OR VIBRATED TO ENSURE THAT BACKFILL AGGREGATE/STONE MATERIAL IS WELL SEATED AND PROPERLY INTER LOCKED. CARE SHALL BE TAKEN TO PREVENT ANY WEDGING ACTION AGAINST THE STRUCTURE. AND ALL SLOPES WITHIN THE AREA TO BE BACKFILLED MUST BE STEPPED OR SERRATED TO PREVENT WEDGING ACTION. CARE SHALL ALSO BE TAKEN AS NOT TO DISRUPT THE JOINT WRAP FROM THE JOINT DURING THE BACKFILL PROCESS. BACKFILL MATERIAL SHALL BE CLEAN, CRUSHED, ANGULAR No. 5 (AASHTO M43) AGGREGATE. IF NATIVE EARTH IS SUSCEPTIBLE TO MIGRATION, CONFIRM WITH GEOTECHNICAL ENGINEER AND PROVIDE PROTECTION AS REQUIRED.
2. DURING PLACEMENT OF MATERIAL OVERTOP THE SYSTEM, AT NO TIME SHALL MACHINERY BE USED OVERTOP THAT EXCEEDS THE DESIGN LIMITATIONS OF THE SYSTEM. WHEN PLACEMENT OF MATERIAL OVERTOP, MATERIAL SHALL BE PLACED SUCH THAT THE DIRECTION OF PLACEMENT IS PARALLEL WITH THE OVERALL LONGITUDINAL DIRECTION OF THE SYSTEM WHENEVER POSSIBLE.
3. THE FILL PLACED OVERTOP THE SYSTEM SHALL BE PLACED AT A MINIMUM OF 6" LIFTS. AT NO TIME SHALL MACHINERY OR VEHICLES GREATER THAN THE DESIGN HS-20 LOADING CRITERIA TRAVEL OVERTOP THE SYSTEM WITHOUT THE MINIMUM DESIGN COVERAGE. IF TRAVEL IS NECESSARY OVERTOP THE SYSTEM PRIOR TO ACHIEVING THE MINIMUM DESIGN COVER, IT MAY BE NECESSARY TO REDUCE THE ULTIMATE LOAD/BURDEN OF THE OPERATING MACHINERY SO AS TO NOT EXCEED THE DESIGN CAPACITY OF THE SYSTEM. IN SOME CASES, IN ORDER TO ACHIEVE REQUIRED COMPACTION, HAND COMPACTION MAY BE NECESSARY IN ORDER NOT TO EXCEED THE ALLOTTED DESIGN LOADING.

StormTrap®

PATENTS LISTED AT: [HTTP://STORMTRAP.COM/PATENT/](http://stormtrap.com/patent/)

1-877-867-6872

ENGINEER INFORMATION:

--

PROJECT INFORMATION:

SINGLETRAP
DETENTION

CURRENT ISSUE DATE:

--

ISSUED FOR:

SAMPLE PROJECT

REV.	DATE:	ISSUED FOR:	DWN BY:

SCALE:

NTS

SHEET TITLE:

SINGLETRAP BACKFILL SPECIFICATIONS
--

SHEET NUMBER:

4.0

GEOFABRIC/ GEOTEXTILE OR EQUAL (SEE NOTE 1)

GEOFABRIC/ GEOTEXTILE OR EQUAL (SEE NOTE 1)

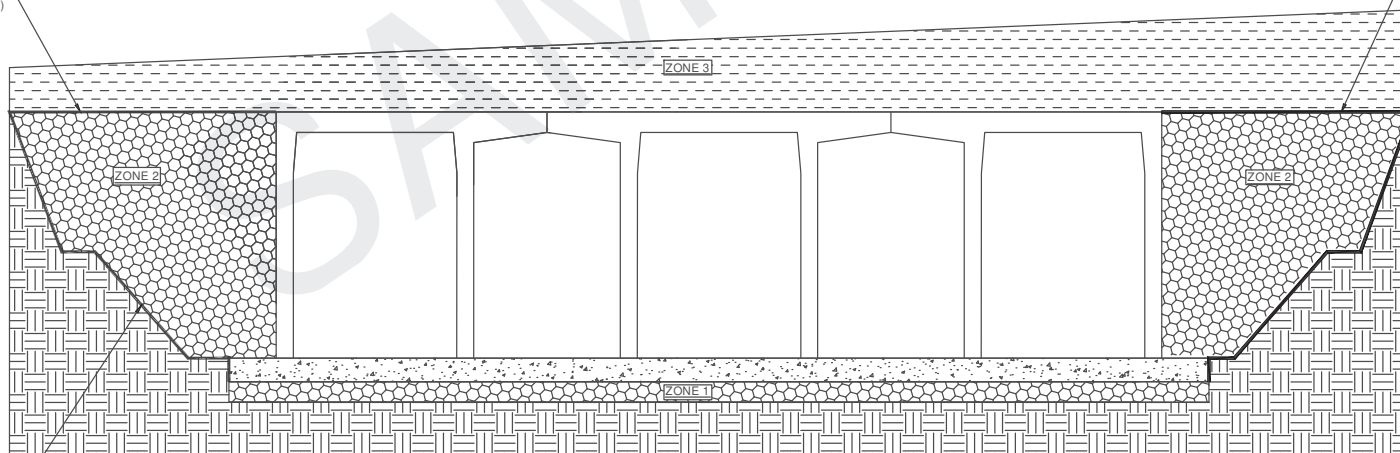

STEPPED OR SERRATED AND APPLICABLE OSHA REQUIREMENTS (SEE BACKFILL NOTE 1)

BACKFILL DETAIL

**RECOMMENDED
ACCESS OPENING SPECIFICATION**

StormTrap®
 PATENTS LISTED AT: [HTTP://STORMTRAP.COM/PATENT/](http://stormtrap.com/patent/)
 1-877-867-6872

ENGINEER INFORMATION:

PROJECT INFORMATION:

SINGLETRAP
 DETENTION

CURRENT ISSUE DATE:

ISSUED FOR:

SAMPLE PROJECT

REV.	DATE:	ISSUED FOR:	DWN BY:

SCALE:

NTS

SHEET TITLE:

RECOMMENDED
 PIPE / ACCESS
 OPENING
 SPECIFICATIONS

SHEET NUMBER:

5.0

1. A TYPICAL ACCESS OPENING FOR THE STORMTRAP SYSTEM ARE 2'-0" IN DIAMETER. ACCESS OPENINGS LARGER THAN 3'-0" IN DIAMETER NEED TO BE APPROVED BY STORMTRAP. ALL OPENINGS MUST RETAIN AT LEAST 1'-0" OF CLEARANCE FROM THE END OF THE STORMTRAP MODULE UNLESS NOTED OTHERWISE. ALL ACCESS OPENINGS TO BE LOCATED ON INSIDE LEG UNLESS OTHERWISE SPECIFIED.
2. PLASTIC COATED STEEL STEPS PRODUCED BY M.A. INDUSTRIES PART #PS3-PFC OR APPROVED EQUAL (SEE STEP DETAIL) ARE PROVIDED INSIDE ANY MODULE WHERE DEEMED NECESSARY. THE HIGHEST STEP IN THE MODULE IS TO BE PLACED A DISTANCE OF 1'-0" FROM THE INSIDE EDGE OF THE STORMTRAP MODULES. ALL ENSUING STEPS SHALL BE PLACED WITH A MAXIMUM DISTANCE OF 1'-4" BETWEEN THEM. STEPS MAY BE MOVED OR ALTERED TO AVOID OPENINGS OR OTHER IRREGULARITIES IN THE MODULE.
3. STORMTRAP LIFTING INSERTS MAY BE RELOCATED TO AVOID INTERFERENCE WITH ACCESS OPENINGS OR THE CENTER OF GRAVITY OF THE MODULE AS NEEDED.
4. STORMTRAP ACCESS OPENINGS MAY BE RELOCATED TO AVOID INTERFERENCE WITH INLET AND/OR OUTLET PIPE OPENINGS SO PLACEMENT OF STEPS IS ATTAINABLE.
5. ACCESS OPENINGS SHOULD BE LOCATED IN ORDER TO MEET THE APPROPRIATE MUNICIPAL REQUIREMENTS. STORMTRAP RECOMMENDS AT LEAST TWO ACCESS OPENINGS PER SYSTEM FOR ACCESS AND INSPECTION.
6. USE PRECAST ADJUSTING RINGS AS NEEDED TO MEET GRADE. STORMTRAP RECOMMENDS FOR COVER OVER 2' TO USE PRECAST BARREL OR CONE INSPECTIONS. (PROVIDED BY OTHERS)

PRECAST CONCRETE ADJUSTING RINGS, BARREL OR CONE SECTIONS AS NEEDED SEE RECOMMENDED ACCESS OPENING SPECIFICATION NOTE 6. (SUPPLIED BY OTHERS)

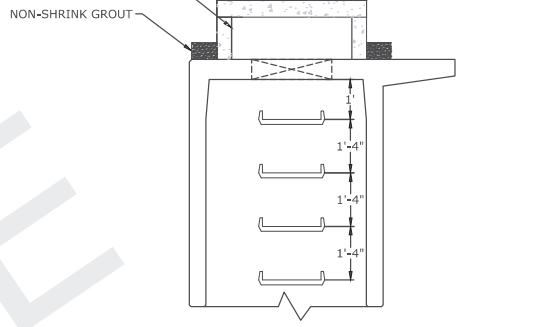

RISER / STAIR DETAIL

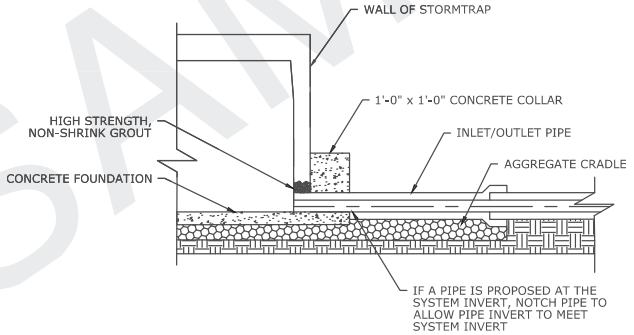
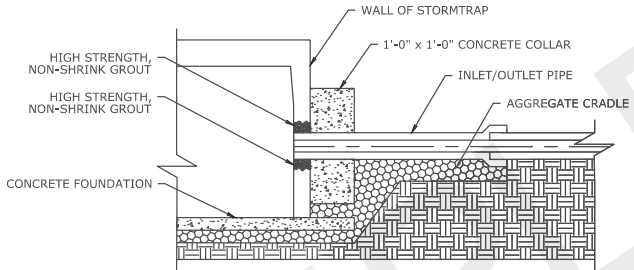

PIPE CONNECTION DETAIL

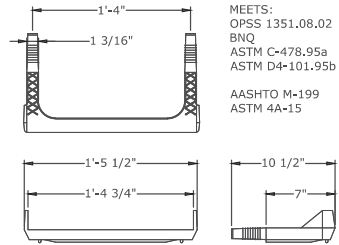

STEP DETAIL

**RECOMMENDED
PIPE OPENING SPECIFICATION**

1. MINIMUM EDGE DISTANCE FOR AN OPENING ON THE OUTSIDE WALL SHALL BE NO LESS THAN 1'-0".
2. MAXIMUM OPENING SIZE TO BE DETERMINED BY THE MODULE HEIGHT. PREFERRED OPENING SIZE Ø 36" OR LESS. ANY OPENING NEEDED THAT DOES NOT FIT THIS CRITERIA SHALL BE BROUGHT TO THE ATTENTION OF STORMTRAP FOR REVIEW.
3. CONNECTING PIPES SHALL BE INSTALLED WITH A 1'-0" CONCRETE COLLAR, AND AN AGGREGATE CRADLE FOR AT LEAST ONE PIPE LENGTH (SEE PIPE CONNECTION DETAIL). A STRUCTURAL GRADE CONCRETE OR HIGH STRENGTH, NON-SHRINK GROUT WITH A MINIMUM 28 DAY COMPRESSIVE STRENGTH OF 3000 PST SHALL BE USED.
4. THE ANNULAR SPACE BETWEEN THE PIPE AND THE HOLE SHALL BE FILLED WITH HIGH STRENGTH NON-SHRINK GROUT.

**RECOMMENDED PIPE
INSTALLATION INSTRUCTIONS**

1. CLEAN AND LIGHTLY LUBRICATE ALL OF THE PIPE TO BE INSERTED INTO STORMTRAP.
2. IF PIPE IS CUT, CARE SHOULD BE TAKEN TO ALLOW NO SHARP EDGES. BEVEL AND LUBRICATE LEAD END OF PIPE.
3. ALIGN CENTER OF PIPE TO CORRECT ELEVATION AND INSERT INTO OPENING.

NOTE: ALL ANCILLARY PRODUCTS RECOMMENDED AND SHOWN ON THIS SHEET ARE RECOMMENDATIONS ONLY AND SUBJECT TO CHANGE PER THE INSTALLING CONTRACTOR.

StormTrap®

PATENTS LISTED AT: [HTTP://STORMTRAP.COM/PATENT]

1-877-867-6872

ENGINEER INFORMATION:

PROJECT INFORMATION:

SINGLETRAP
DETENTION

CURRENT ISSUE DATE:

ISSUED FOR:

SAMPLE PROJECT

REV.	DATE:	ISSUED FOR:	DWN BY:

SCALE:

NTS

SHEET TITLE:

SINGLETRAP
MODULE TYPES

SHEET NUMBER:

6.0

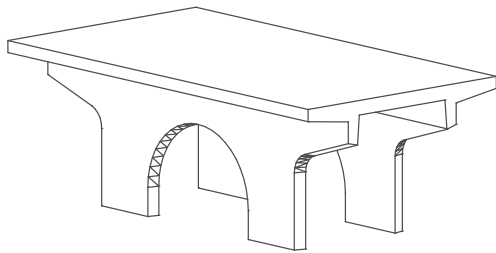

TYPE I

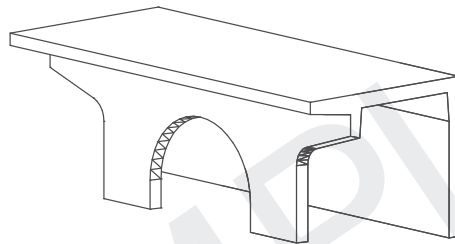

TYPE III

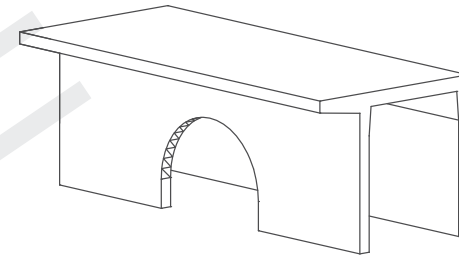

TYPE IV

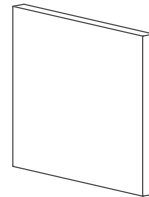

TYPE IV
END PANEL

SAMPLE

NOTES:

1. OPENING LOCATIONS AND SHAPES MAY VARY.
2. SP - INDICATES A MODULE WITH MODIFICATIONS.
3. P - INDICATES A MODULE WITH A PANEL ATTACHMENT.
4. POCKET WINDOW OPENINGS ARE OPTIONAL.